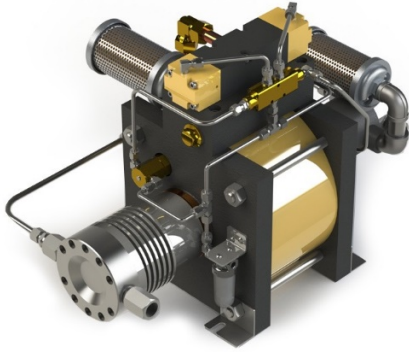

TECHNICAL DATA SHEET

PRODUCT	PU-GBD7/33-L**/options	
SERIES	2-Stage Double Acting Air operated, high flow gas booster compressors offer a flexible and efficient source for delivering high pressure gases.	

FEATURES

- Infinitely variable output pressure and flow
- Will hold static pressure without generating heat or consuming power
- Standard models are suitable for various gases
- Well proven and trouble-free operation
- Designed for ease of maintenance
- Low cost servicing
- Robust construction

PERFORMANCE DATA

Max Rated Output Pressure	5,700psi (393bar)
Displacement Per Cycle	35.8 in ³ (586cc)
Max Flow	6.94 scfm (196 NI/min)
Max Air Supply Pressure	100psi (7bar)
Ratio	60 : 1
Air Consumption	120 scfm (3,400 NI/min)
Supply Pressure to Achieve Max Output Pressure	510psi (35bar)
Actual Output Pressure (Stall Condition)	33 x (Air drive pressure) + 4.7 x (Supply pressure)

SEAL MATERIAL

Main Seals	MoS2
Check Valve Seals	Viton

CONSTRUCTION

Air Motor	Anodised Aluminium / Nitrile (Buna-N) Seals
Gas Cylinder	17-4PH
Piston	Stainless Steel + 17-4PH + Chrome Finish
Check Valves	Stainless Steel
Pilot Air Valves	Brass / Stainless Steel Internals / Nitrile (Buna-N) Seals / Stainless Steel Silencer
L1** (standard)	Copper Air Inlet & Plated Steel Silencer
L2** (optional)	Stainless Steel Air Inlet & Silencer

CONNECTIONS

Gas Inlet	3/8" NPT(F)
Gas Outlet	3/8" NPT(F)
Air Inlet	3/4" NPT(F)
Pilot Air Supply	1/8" BSPP(F)
Net Weight	50kg (110lb)

COMMON OPTIONS (BUT NOT LIMITED TO)

/ A	ATEX (94/9/EC) II 2GD c T5
/ F	Panel mount digital stroke counter (non ATEX)
/ G	Panel mount pneumatic stroke counter

GENERAL LAYOUT DRAWING

Model: **PU-GBD7/33**

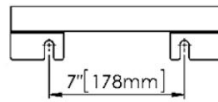
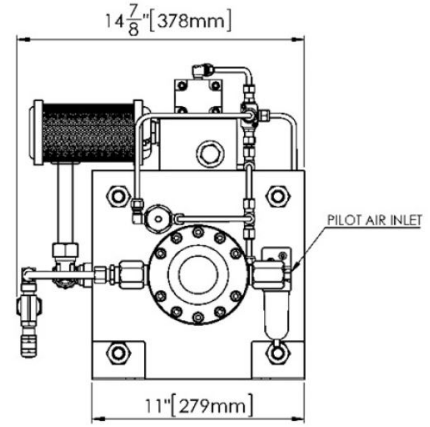
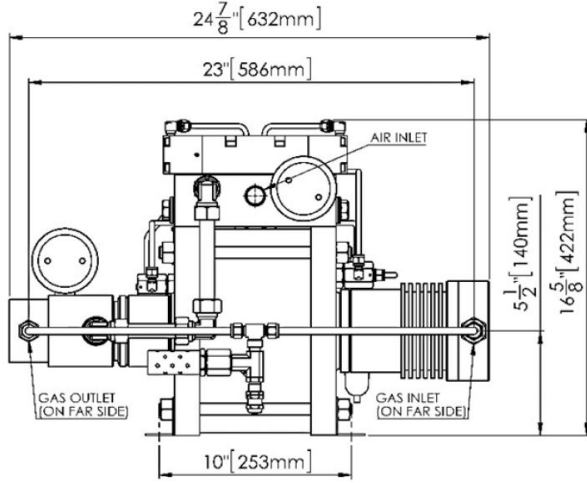

ALL MOUNTED BRACKETS HAVE 11mm (7/16") SLOTS