

TECHNICAL DATA SHEET

PRODUCT	HYPS-AZ-1-140H-N*/**options	
SERIES	HYPS-AZ-1 Single Acting Air operated, hydraulic power pack for pressure testing, chemical injection and hydraulic power.	

FEATURES

- Infinitely variable output pressure and flow
- Holds static pressure without generating heat or consuming power
- Standard models are suitable for oil or water applications
- Well proven and trouble-free operation
- Designed for ease of maintenance & Low cost servicing

Basic Models are ATEX Certified in accordance with 2014/34/EU.

Note: addition of options may affect ATEX rating.

PERFORMANCE DATA

Max Rated Output Pressure	14,000psi (966bar)
Output Per Cycle	0.188 in ³ (3.1cc)
Max Flow	92 in ³ /min (1.51 litre/min)
Max Air Supply Pressure	100psi (7bar)
Ratio	140 : 1
Air Consumption	28 scfm (800 NI/min)
Tank Capacity	2.5 Gallons (11.4 litres)

SEAL OPTIONS (N*)

N*	(Standard) Nitrile (Buna-N) Main Seal and Check Valve Seals
V	Viton (FKM) Main Seal and Check Valve Seals
C	Chemraz (FFKM) Main Seal and Check Valve Seals

CONSTRUCTION

Frame and Tank	Stainless Steel
Air Motor	Anodised Aluminium / Wound Composite / Nitrile (Buna-N)
Hydraulic Cylinder	Stainless Steel
Piston	Stainless Steel + Chrome Finish
Outlet Port	Stainless Steel

CONNECTIONS

Hydraulic Outlet	3/8" MP(F)
Air Inlet	1/2" BSPP(F)
Net Weight	25kg (55lb)

COMMON OPTIONS (BUT NOT LIMITED TO)

/ D	External fluid supply via bulkhead (no tank fitted)
/ T	Stainless steel tank fitted
/ Tx	Stainless steel tank fitted with external fluid supply port
/ F	Panel mount digital stroke counter (non ATEX)
/ G	Panel mount pneumatic stroke counter
/ I	Test isolation valve fitted
/ O	Single pen chart recorder complete with recorder isolation valve
/ W	Fitted with wheels
/ R	Relief valve fitted and set in test line

GENERAL LAYOUT DRAWING

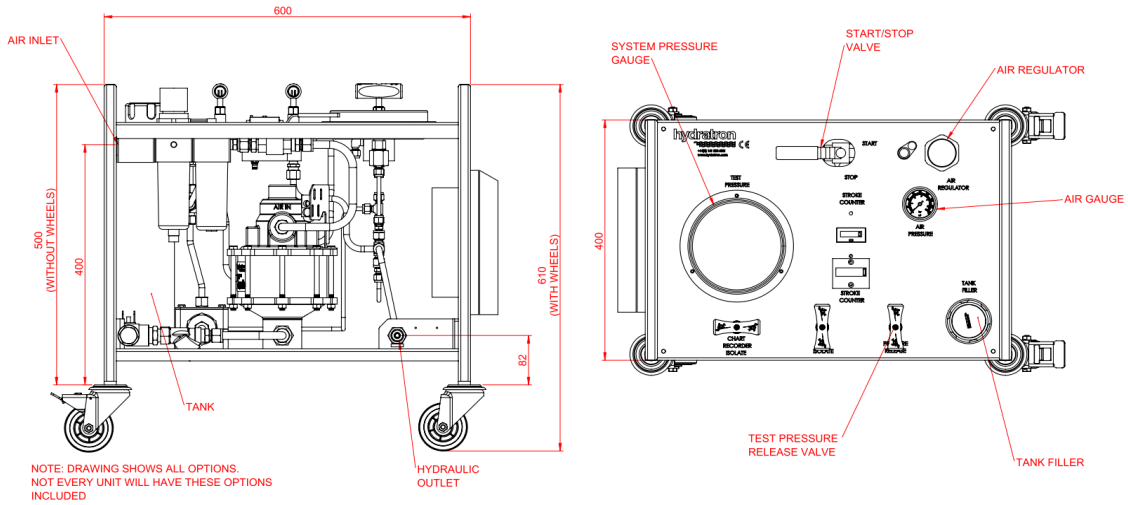

HYDRAULIC PRESSURE STATIC / STALL CONDITIONS

AIR PRESSURE	HYDRAULIC PRESSURE
20psi (1.4bar)	2,400psi (166bar)
40psi (2.8bar)	5,400psi (372bar)
60psi (4bar)	8,300psi (572bar)
80psi (5.5bar)	11,200psi (772bar)
100psi (7bar)	14,000psi (966bar)

FLOW CURVE

HYPS-AZ-1-140 - Ratio 140:1

