

## TECHNICAL DATA SHEET

PRODUCT	<b>HYPs-AZ-1-86H-N*/**options</b>	
SERIES	<b>HYPs-AZ-1 Single Acting</b>  Air operated, hydraulic power pack for pressure testing, chemical injection and hydraulic power.	

### FEATURES

- Infinitely variable output pressure and flow
- Holds static pressure without generating heat or consuming power
- Standard models are suitable for oil or water applications
- Well proven and trouble-free operation
- Designed for ease of maintenance & Low cost servicing

Basic Models are ATEX Certified in accordance with 2014/34/EU.

*Note: addition of options may affect ATEX rating.*

### PERFORMANCE DATA

Max Rated Output Pressure	8,600psi (593bar)
Output Per Cycle	0.31 in <sup>3</sup> (5cc)
Max Flow	185 in <sup>3</sup> /min (3.03 litre/min)
Max Air Supply Pressure	100psi (7bar)
Ratio	86 : 1
Air Consumption	28 scfm (800 NI/min)
Tank Capacity	2.5 Gallons (11.4 litres)

### SEAL OPTIONS (N\*)

N*	(Standard) Nitrile (Buna-N) Main Seal and Check Valve Seals
V	Viton (FKM) Main Seal and Check Valve Seals
C	Chemraz (FFKM) Main Seal and Check Valve Seals

**CONSTRUCTION**

Frame and Tank	Stainless Steel
Air Motor	Anodised Aluminium / Wound Composite / Nitrile (Buna-N)
Hydraulic Cylinder	Stainless Steel
Piston	Stainless Steel + Chrome Finish
Outlet Port	Stainless Steel

**CONNECTIONS**

Hydraulic Outlet	3/8" MP(F)
Air Inlet	1/2" BSPP(F)
Net Weight	25kg (55lb)

**COMMON OPTIONS (BUT NOT LIMITED TO)**

/ D	External fluid supply via bulkhead (no tank fitted)
/ T	Stainless steel tank fitted
/ Tx	Stainless steel tank fitted with external fluid supply port
/ F	Panel mount digital stroke counter (non ATEX)
/ G	Panel mount pneumatic stroke counter
/ I	Test isolation valve fitted
/ O	Single pen chart recorder complete with recorder isolation valve
/ W	Fitted with wheels
/ R	Relief valve fitted and set in test line

## GENERAL LAYOUT DRAWING

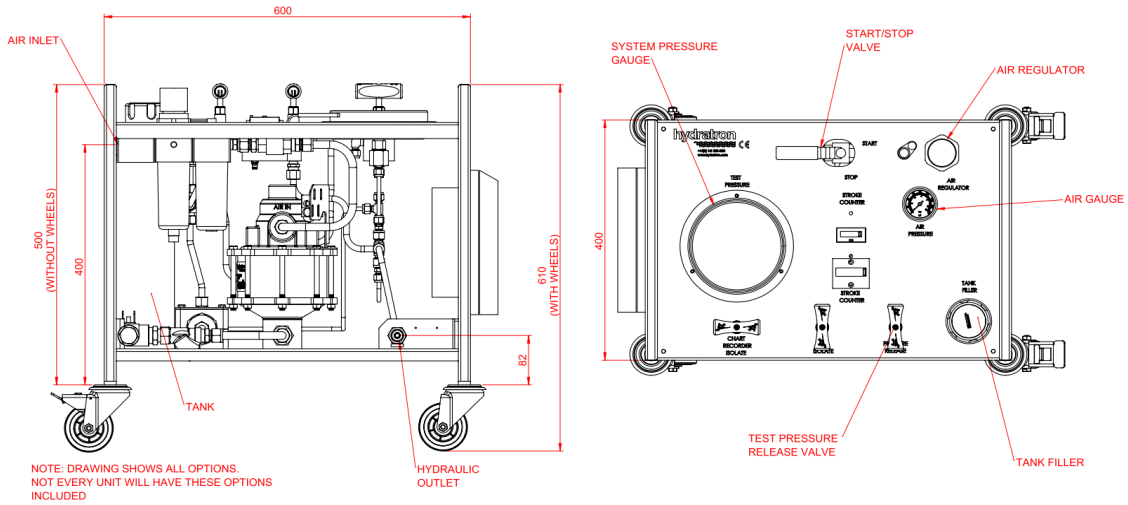

## HYDRAULIC PRESSURE STATIC / STALL CONDITIONS

AIR PRESSURE	HYDRAULIC PRESSURE
20psi (1.4bar)	1,700psi (117bar)
40psi (2.8bar)	3,400psi (234bar)
60psi (4bar)	5,100psi (352bar)
80psi (5.5bar)	6,900psi (476bar)
100psi (7bar)	8,600psi (593bar)

## FLOW CURVE HYPS-AZ-1-86 - Ratio 86:1

