

## TECHNICAL DATA SHEET

PRODUCT	<b>PU-AZ-2-458H-N*-L**/options</b>	
SERIES	<b>AZ-2 Single Acting</b>  Air operated, hydraulic pumps for pressure testing, chemical injection and hydraulic power.	

### FEATURES

- Infinitely variable output pressure and flow
- Will hold static pressure without generating heat or consuming power
- Standard models are suitable for oil or water applications
- Well proven and trouble-free operation

### PERFORMANCE DATA

Max Rated Output Pressure	45,800psi (3,159bar)
Output Per Cycle	0.192 in <sup>3</sup> (3.1cc)
Max Flow	46 in <sup>3</sup> /min (0.75 litre/min)
Max Air Supply Pressure	100psi (7bar)
Ratio	458 : 1
Air Consumption	56 scfm (1,586 NI/min)

### SEAL OPTIONS (N\*)

N* (standard)	Nitrile (Buna-N) Main Seal and Check Valve Seals
V	Viton (FKM) Main Seal and Check Valve Seals
C	Chemraz (FFKM) Main Seal and Check Valve Seals

### CONSTRUCTION

Air Motor	Anodised Aluminium / Wound Composite / Nitrile (Buna-N) Seals
-----------	---

Hydraulic Cylinder	Stainless Steel
Piston	Stainless Steel + Chrome Finish
Check Valves	Stainless Steel (Seals as per Selected Seal Option)
L1** (standard)	Plated Steel Air Motor Studs
L2** (optional)	Stainless Steel Air Motor Studs

## CONNECTIONS

Hydraulic Inlet	3/8" NPT(F)
Hydraulic Outlet	1/4" HP(F)
Air Inlet	1/2" NPT(F)
Silencer Air Outlet	1" NPT(F)
Net Weight	9kg (20lb)

## COMMON OPTIONS (BUT NOT LIMITED TO)

/ A	ATEX - Zone 1 Category II
/ L	Low pressure start for air motor
/ N	Greased for life lubricated air motor

## GENERAL LAYOUT DRAWING

Model: PU-AZ-2-458H

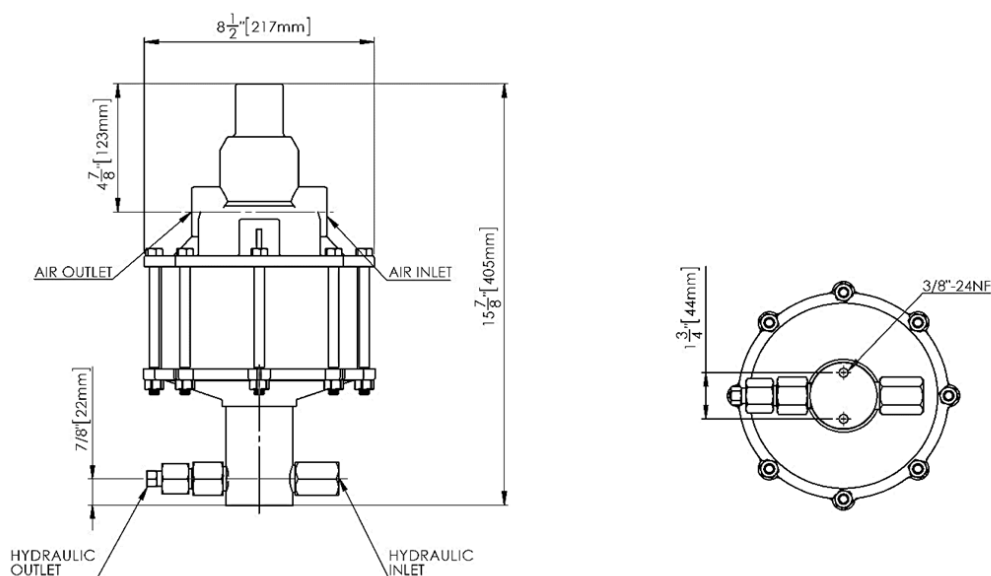

**HYDRAULIC PRESSURE STATIC / STALL CONDITIONS**

AIR PRESSURE	HYDRAULIC PRESSURE
20psi (1.4bar)	8,800psi (607bar)
40psi (2.8bar)	18,000psi (1,241bar)
60psi (4bar)	27,000psi (1,862bar)
80psi (5.5bar)	36,500psi (2,517bar)
100psi (7bar)	45,800psi (3,159bar)

**FLOW CURVE** AZ-2-458 - Ratio 458:1

