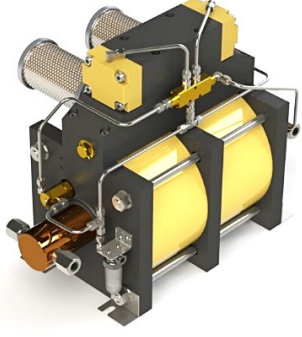

TECHNICAL DATA SHEET

PRODUCT	PU-DHDA158/4-N*-L1**/options	
SERIES	DHDA Double Airhead Double Acting Air operated, high flow, double headed-double acting hydraulic pumps for pressure testing, chemical injection and hydraulic power.	

FEATURES

- Infinitely variable output pressure and flow
- Holds static pressure without generating heat or consuming power
- Standard models are suitable for oil or water applications
- Well proven and trouble-free operation
- Designed for ease of maintenance
- Low cost servicing
- Robust construction

PERFORMANCE DATA

Max Rated Output Pressure	30,000psi (2,069bar)
Output Per Cycle	3.4 in ³ (55cc)
Max Flow	393 in ³ /min (6.4 litre/min)
Max Air Supply Pressure	100psi (7bar)
Ratio	316 : 1
Air Consumption	200 scfm (5,664 NI/min)

SEAL OPTIONS (N*)

N* (standard)	PTFE Main Seal & Nitrile (Buna-N) Check Valve Seals
V	PTFE Main Seal & Viton (FKM) Check Valve Seals
C	PTFE Main Seal & Chemraz (FFKM) Check Valve Seals (Max Rated Output Pressure 15,000psi (1035bar))

CONSTRUCTION

Air Motor	Anodised Aluminium / Nitrile (Buna-N) Seals
-----------	---

Hydraulic Cylinder	Aluminium Bronze
Piston	17-4PH + Corrosion Resistant Chrome Finish
Check Valves	Stainless Steel (Seals as per Selected Seal Option)
Pilot Air Valves	Brass / Stainless Steel Internals / Nitrile (Buna-N) Seals / Stainless Steel Pipework
L1** (standard)	Plated Steel Silencer
L2** (optional)	Stainless Steel Silencer

CONNECTIONS

Hydraulic Inlet	1/2" NPT(F)
Hydraulic Outlet	9/16" HP(F)
Air Inlet	1" NPT(F)
Pilot Air Supply	1/8" BSPP(F)
Net Weight	69kg (152lb)

COMMON OPTIONS (BUT NOT LIMITED TO)

/ A	ATEX - Zone 1 Category II
/ F	Panel mount digital stroke counter (non ATEX)
/ G	Panel mount pneumatic stroke counter

GENERAL LAYOUT DRAWING Model: PU-DHDA158/4

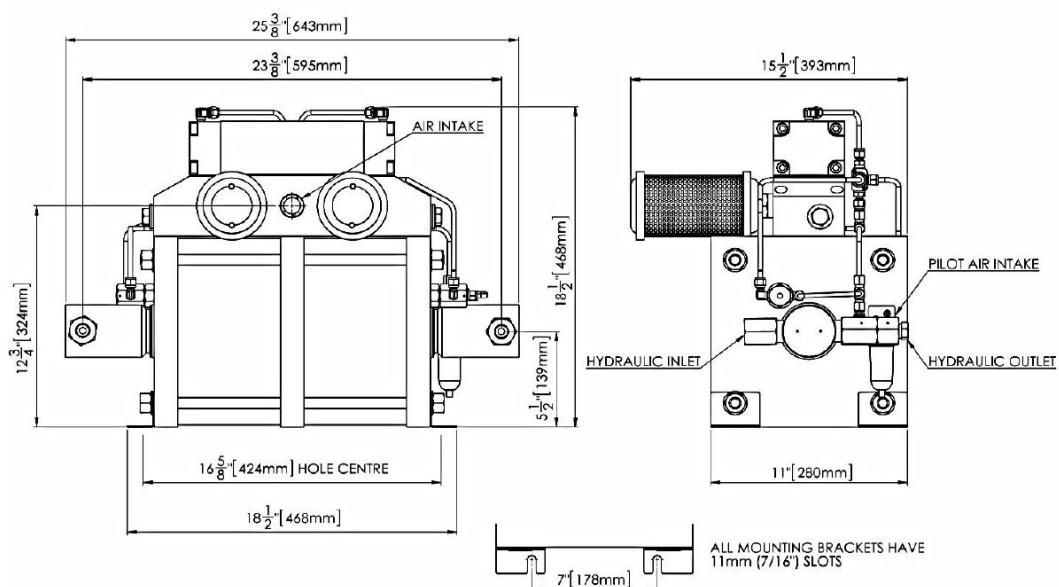

HYDRAULIC PRESSURE STATIC / STALL CONDITIONS

AIR PRESSURE	HYDRAULIC PRESSURE
20psi (1.4bar)	6,320psi (436bar)
40psi (2.8bar)	12,640psi (871bar)
60psi (4bar)	18,960psi (1,307bar)
80psi (5.5bar)	25,280psi (1,743bar)
100psi (7bar)	30,000psi (2,069bar)

FLOW CURVE DHDA158 – Ratio 316:1

